

THIS DRAWING IS UNPUBLISHED. RELEASED FOR PUBLICATION
 (C) COPYRIGHT 19 BY AMP INCORPORATED. ALL RIGHTS RESERVED.

LOC		DIST		REVISIONS			
P	LTR	DESCRIPTION	DATE	DWN	APVD		
AF	50	B	REVISED PER 063A-0171-02	11APR02	MF	KR	

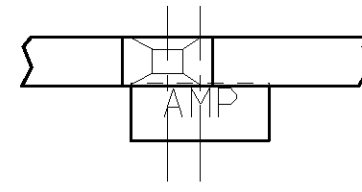

- 1 CONTINUOUS STRIP ON REELS WITH TERMINALS LOCATED ON 5.08±0.08 [.200±.003] CENTERS.
- 2 SLOT ACCEPTS 0.36-0.45mm [#27-#25] AWG COPPER MAGNET WIRE
- 3 IDENTIFICATION NUMBER 9 FOR WIRE SLOT SIZE.
- 4 0.002032 [.000080] MIN TIN PLATE OVER 0.00254 [.000100] MIN COPPER UNDERPLATE.

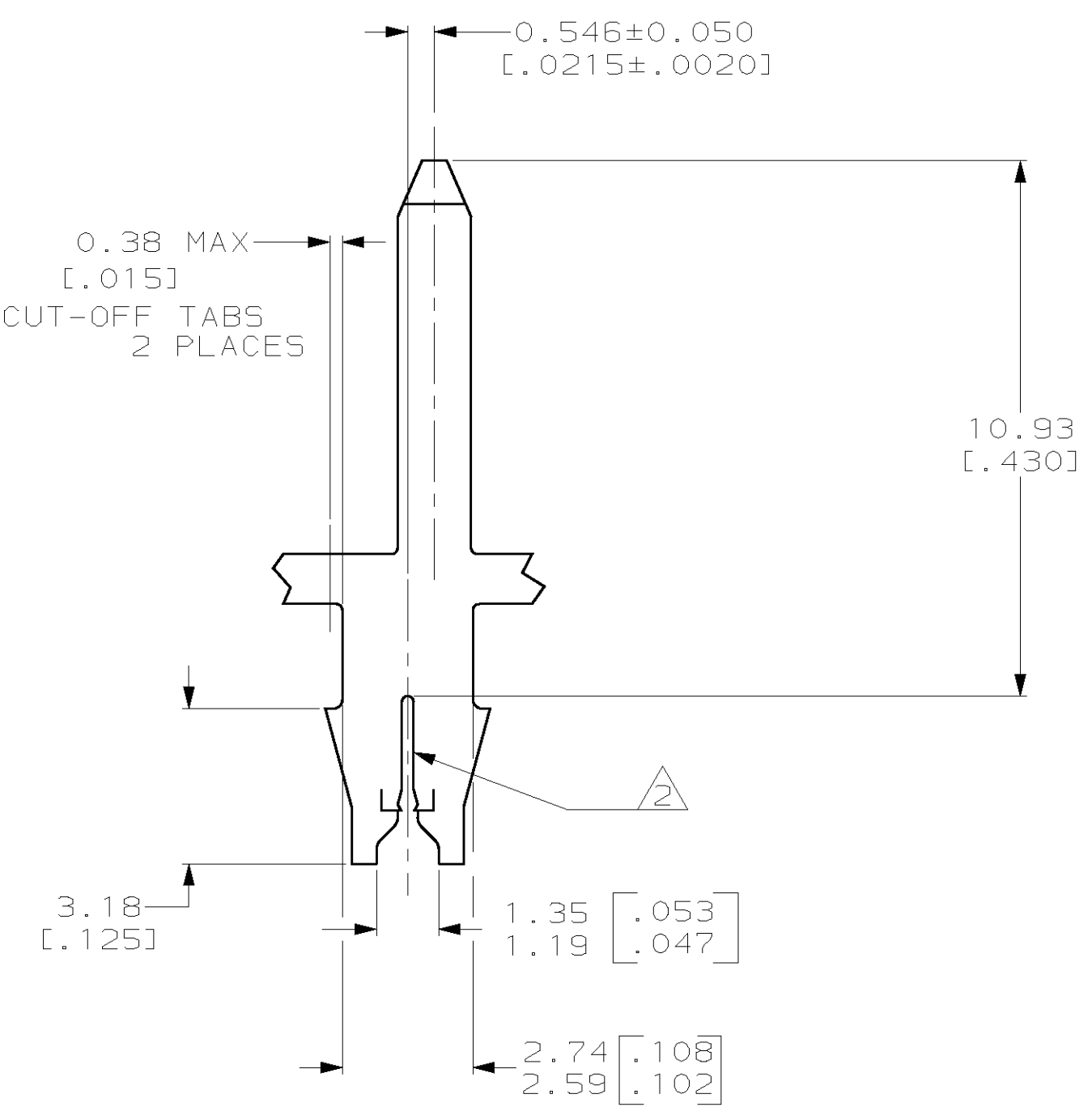
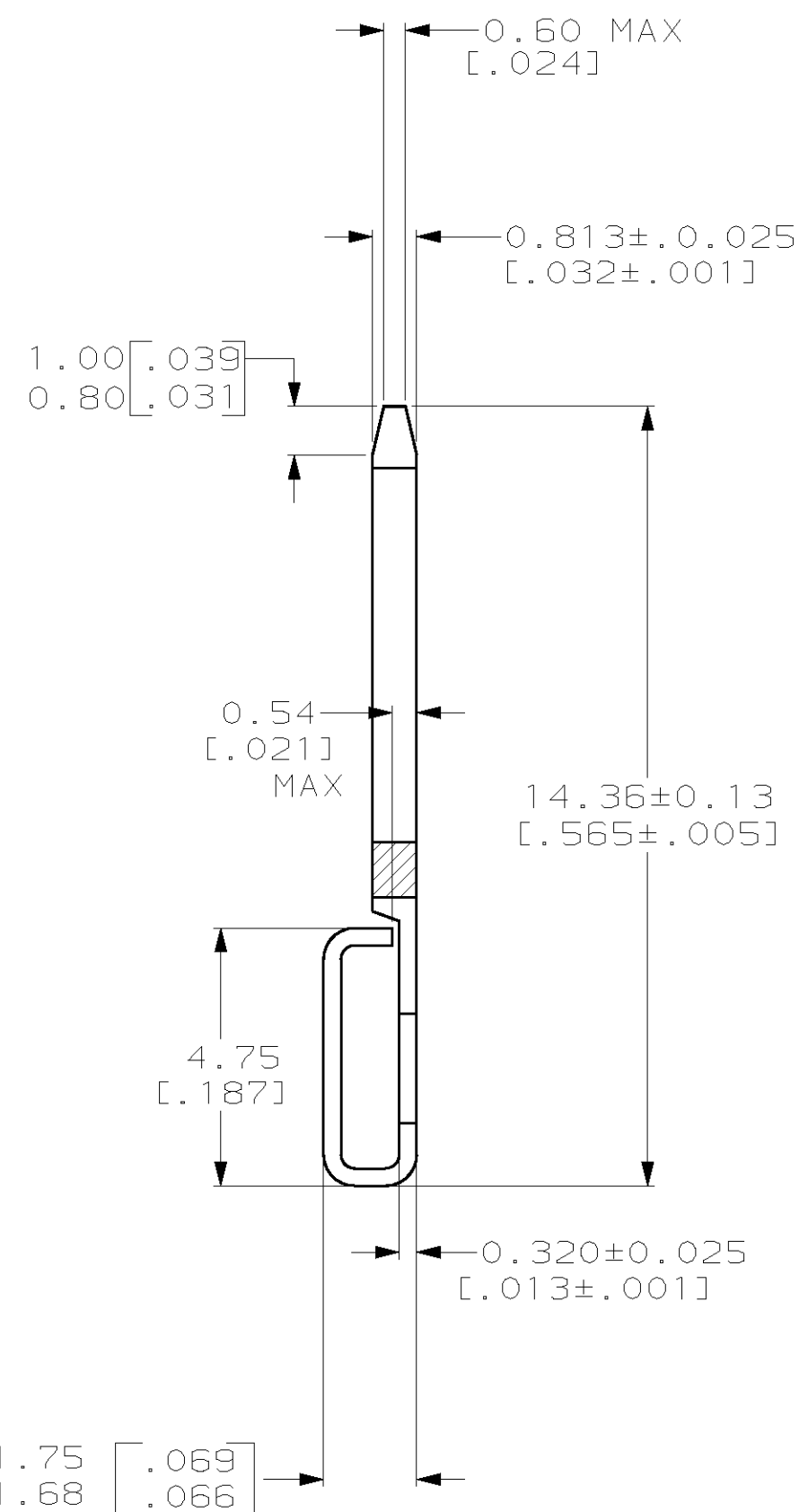
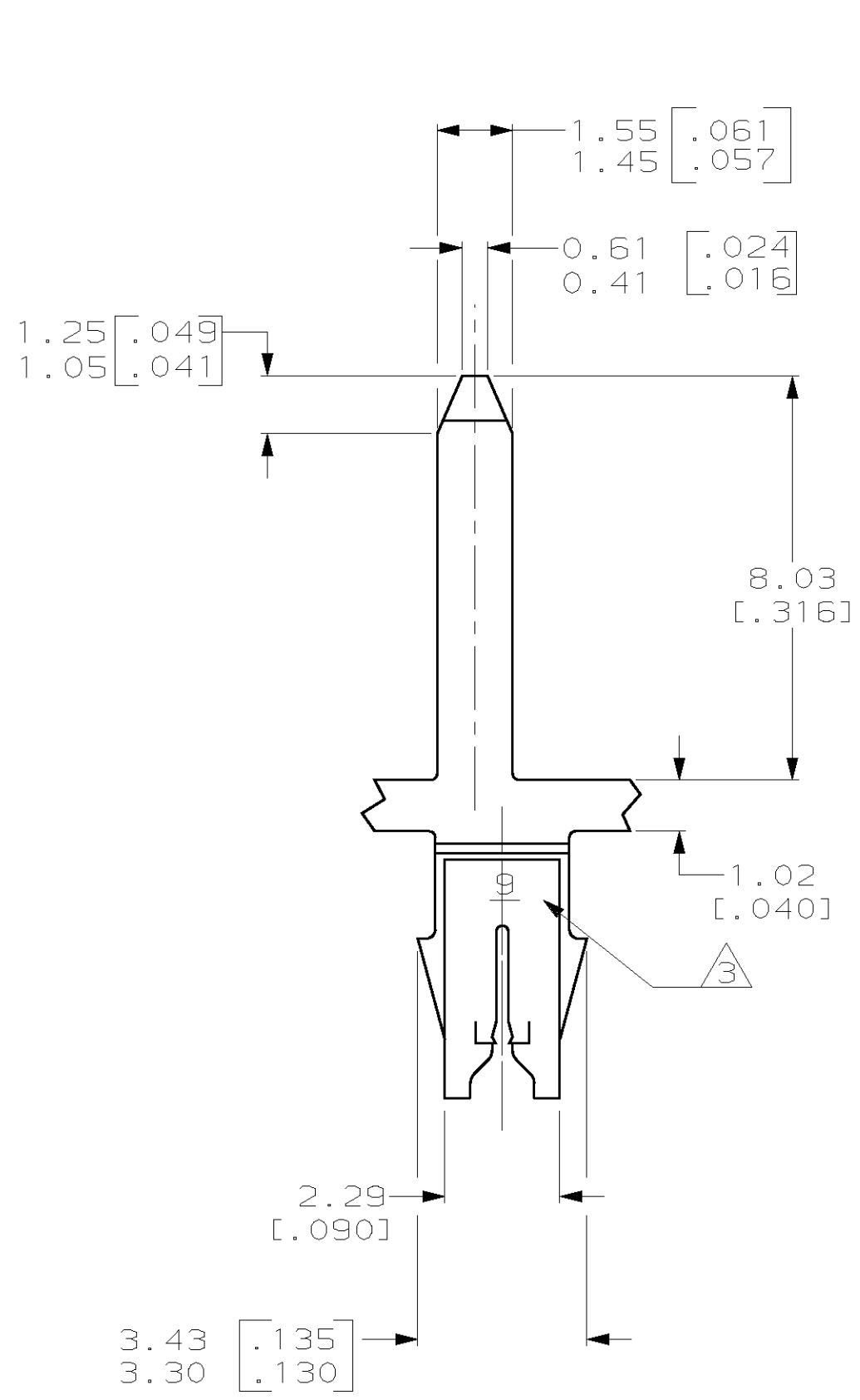

1217642-1
PART NUMBER

THIS DRAWING IS A CONTROLLED DOCUMENT.		DWN	15MAY2001	AMP Incorporated Harrisburg, PA 17105-3608							
DIMENSIONS: mm [INCHES]		CHK	15MAY2001								
TOLERANCES UNLESS OTHERWISE SPECIFIED:		APVD	15MAY2001								
0 PLC ±- 1 PLC ±- 2 PLC ±0.25 [.010] 3 PLC ±- 4 PLC ±- ANGLES ±-		NAME	KURT A. RANDOLPH								
MATERIAL H04 PRE-MILLED BRASS		PRODUCT SPEC	108-2012	SIZE	A2	CAGE CODE	00779	DRAWING NO	1217642	RESTRICTED TO	-
FINISH 4 -		APPLICATION SPEC	114-2069	WEIGHT	-	SCALE	8:1	SHEET	1 OF 1	REV	B
		CUSTOMER DRAWING									